

# CONSOLIDATED DESIGN OF THE 17 MeV INJECTOR FOR MYRRHA\*

D. Mäder<sup>†</sup>, D. Koser, H. Podlech, A.Schempp, IAP, Goethe-Universität, Frankfurt am Main, Germany

## Abstract

The MYRRHA research reactor will be an Accelerator Driven System (ADS), which demands a 2.4 MW proton beam delivered by a 600 MeV cw operated linac [1]. The beam dynamics design of the injector has been consolidated to fulfil the requirements with respect to beam losses and quality [2].

After a 4-rod-RFQ [3], four 7-gap room temperature CH cavities with a constant phase and an effective voltage of 750 keV are used to reach 4.3 MeV. Then the proton beam is accelerated to 18 MeV using eight superconducting 5-gap Nb CH structures with a constant beta profile. With reducing the gradient and adjusting the phase of the 12<sup>th</sup> CH structure the originally demanded 17 MeV can be delivered, too.

Every SC CH cavity is cooled down to 2K with liquid helium in a separate cryo module. The new geometric design of the SC CH cavities improves the rigidity and reduces the electric peak field.

## MOTIVATION

For the MYRRHA injector a very compact and efficient KONUS beam dynamics design could be found [4]. To increase the longitudinal acceptance of each cavity the new consolidated beam dynamics are based on shorter cavities with constant phase profile in the RT section and constant beta profile in the SC section (Figure 1).

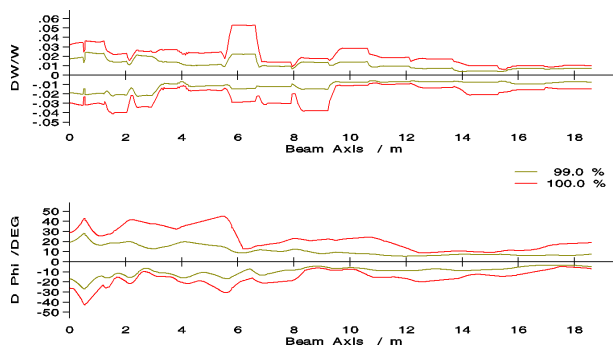

Figure 1: Longitudinal centered beam envelope.

Furthermore the use of multiple diagnostic elements has been considered for fast failure detection (Figure 4). With monitoring the beam quality after each CH structure particle losses in the main linac could be minimized.

The increased number of cavities, the diagnostics and the use of shorter cryomodules, with only one SC cavity inside

\*Work supported by the EU, FP7 MAX, contract No. 269565 and BMBF, contract No. 06FY7102.

<sup>†</sup> d.maeder@iap.uni-frankfurt.de

and RT triplet lenses in between, result in a total injector length of 22.2 m instead of 12.6 m.

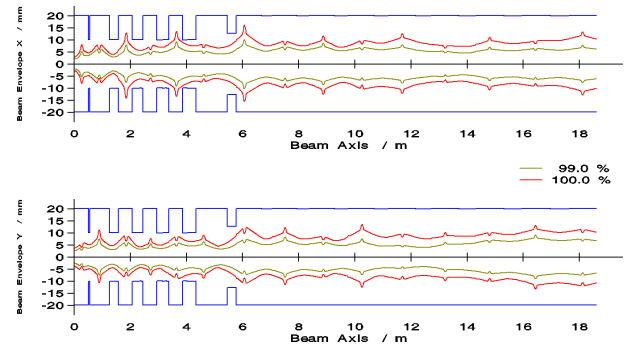

Figure 2: Transversal beam envelope.

## RESULTS

### Beam Dynamics

The new consolidated design has an improved longitudinal output distribution. Compared to the KONUS beam dynamics design [4] the phase spread 1 m behind the last accelerating gap is 24 % smaller. The longitudinal normal rms emittance growth could be reduced from 35 % to 14 % although the consolidated design consists of longer drift sections (Figure 3).

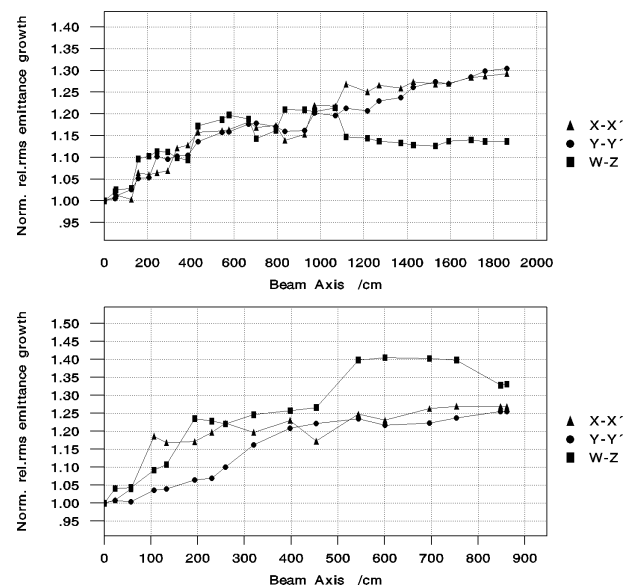

Figure 3: The Emittance growth in the consolidated beam dynamics design (upper graph) is lower than in the KONUS beam dynamics design (lower graph [4]).

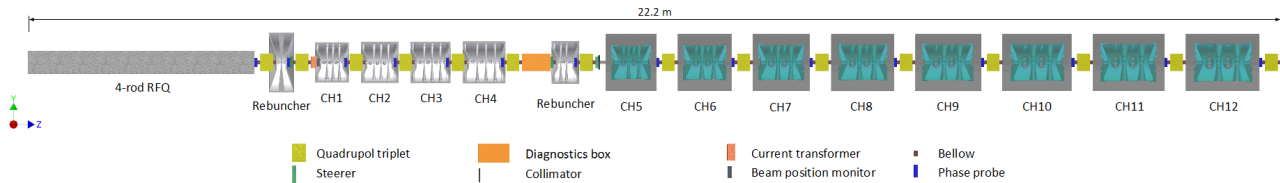

Figure 4: An overview of the 22.2 m long MYRRHA injector layout with phase probes after each cavity. Every SC CH structure (turquoise) has its own cryomodule (grey). The second Rebuncher needs to be designed and added to the overview (placeholder used).

Table 1: Parameters of RT CH Structures

	CH1	CH2	CH3	CH4
Frequency [MHz]	176.1	176.1	176.1	176.1
$\phi_{sync} [^\circ]$	-12	-18	-18	-18
$U_{eff}$ [MV]	0.75	0.75	0.75	0.75
Cavity radius [mm]	322.2	328.8	334.0	338.5
Cavity length ( $\beta\lambda$ -definition) [mm]	536.2	596.9	648.6	695.2
Q-factor	16836	17463	17768	17979
$P_{sim.}$ [kW]	12.9	11.3	11.2	11.2
$P_{norm. (95\%)}$ [kW]	13.6	11.9	11.8	11.8
$P_{norm./l (95\%)}$ [kW/m]	25.3	19.9	18.1	16.9
$\beta_{avg.}$	0.063	0.074	0.083	0.092
$\beta\lambda/2$ [mm]	53.9	63.2	70.9	78.0
$R_a$ [M $\Omega$ ]	43.7	49.9	50.3	50.3
$Z_a$ [M $\Omega$ /m]	81.5	83.6	77.6	72.4

Within this drift space the repulsive space charge effects are getting severe. To reduce the transit time of the protons in the long drifts the following concepts are applied:

- The cavities after the rebunchers have a slightly negative phase (e.g.  $-12^\circ$  in CH1, table 1). This maximizes the energy gain though the effective voltages are limited due to the conservative design.
- The synchronous particle in CH1 has a energy of 1.485 MeV instead of the delivered 1.5 MeV of the RFQ. Slower protons can be caught longitudinally before getting lost during the drift to CH2.
- The transition energy from the RT to the SC cavities is increased by 0.7 MeV. Hence the protons are faster in the long drift between the SC cavities and its cryostats.
- Quadrupole triplet lenses between every RF cavity are necessary to keep the transversal beam envelope small (Figure 2).

### RT CH Cavities

In the consolidated design the room temperature CH cavities consist of 7 instead of 10 accelerating gaps. Cavities with less gaps facilitate the commissioning. Less than 7 gaps would result in particle losses with the given RFQ output distribution. The expected thermal losses of the room temperature CH structures are below 14 kW (Table 1).

### 01 Progress reports and Ongoing Projects

### N. Technical R&D - Overall performances (cavity, proto cryomodule tests)

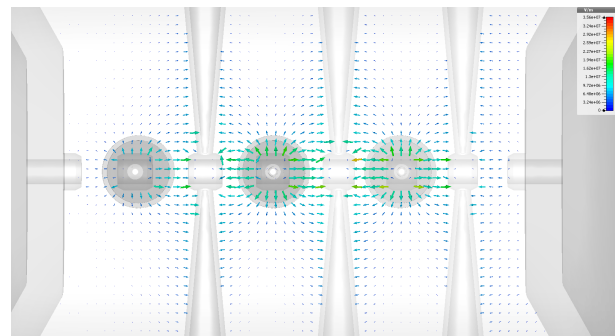

Figure 5: Simulated linear scaled electric field distribution (zy-plane) of CH1. Only straight stems are used for simplification.

To save drift spaces the end walls of the RT CH structures are cone shaped. The inclined stem design which increases the shunt impedance [5] has been removed for simplification (Figure 5 and 6).

### SC CH Cavities

Eight superconducting CH cavities, each with an accelerating voltage of approximately 2 MV and a constant beta profile, accelerate the proton beam by 13.8 MeV. Electric peak fields below 25 MV/m ensure a high reliability. CH6 to CH12 are markedly below this limit. But the magnetic peak fields don't exceed 40 mT, which is a very conservative value for safe operation (Table 2).

Table 2: Parameters of SC CH Structures

	CH5	CH6	CH7	CH8	CH9	CH10	CH11	CH12
Frequency [MHz]	176.1	176.1	176.1	176.1	176.1	176.1	176.1	176.1
$\beta_{\text{design}}$	0.106	0.122	0.136	0.148	0.160	0.171	0.181	0.190
$\beta_{\text{in}}$	0.095	0.114	0.129	0.141	0.153	0.165	0.176	0.185
$\beta_{\text{out}}$	0.114	0.129	0.141	0.153	0.165	0.176	0.185	0.194
Cavity radius [mm]	283.3	290.8	297.2	303.6	309.5	315.3	320.7	325.5
Cavity length ( $\beta\lambda$ -definition) [mm]	450.4	520.4	576.9	630.0	679.7	727.2	771.0	810.1
$U_{\text{eff}}$ [MV]	1.90	1.92	1.93	1.93	1.92	1.93	1.93	1.93
$E_a$ [MV/m]	4.22	3.69	3.35	3.06	2.83	2.65	2.50	2.51
$E_p$ [MV/m]	24.36	19.45	17.62	15.92	14.90	13.72	13.22	13.15
$E_p/E_a$	5.77	5.27	5.26	5.20	5.25	5.18	5.29	5.24
$B_p/E_a$ [mT/(MV/m)]	9.23	9.69	10.64	11.64	12.27	12.73	13.6	14.8
$R_a/Q$ [ $\Omega$ ]	625.7	600.7	576.4	562.5	546.5	532.0	513.0	502.2
$R_a R_s$ [ $\Omega^2$ ]	33409	33586	33023	32983	32550	32180	31366	30943
$R_s Q$ [ $\Omega$ ]	53.4	55.9	57.3	58.6	59.6	60.5	61.1	61.6

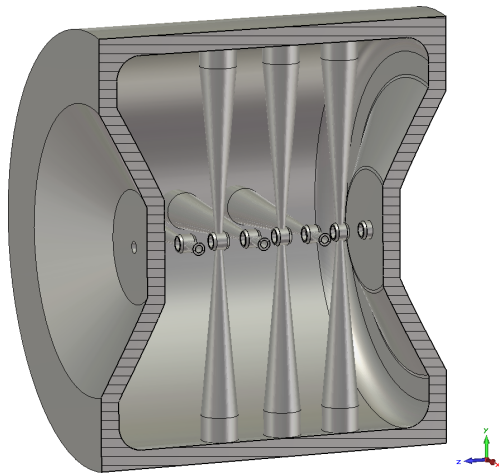

Figure 6: 3D model of CH1 with 6 stems and cone shaped end walls.

Evacuation of the cavity induces a pressure of 100 kPa (atmospheric pressure). Radial arranged braces minimize the deformation of the 4 mm thin Nb walls (Figure 7).

With this innovative stabilizer geometry the maximum displacement is below 0.16 mm and the peak Von-Mises-Stress is reduced to 63 MPa.

## OUTLOOK

The consolidated beam dynamics design is extremely promising. The longitudinal phase distribution could be improved without particle losses in the LORASR simulations. Misalignments of accelerators, bunchers and magnets and their effects on the beam dynamics will be studied in the near future.

## ACKNOWLEDGMENT

This work has been supported by the EU, FP7 MAX, contract No. 269565 and BMBF, contract No. 06FY7102.

ISBN 978-3-95450-143-4

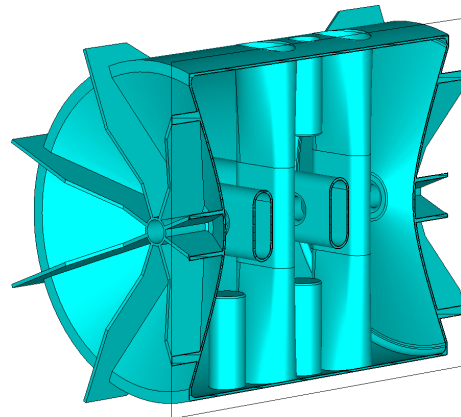

Figure 7: Cylindric mainly capacitive tuners are placed between the stems of CH5.

## REFERENCES

- [1] J.-L. Biarrotte, A.C. Mueller, H. Klein, P. Pierini, D. Vandeplassche, "Accelerator reference design for the MYRRHA European ADS demonstrator", LINAC2010, Tsukuba, Japan, September 2010, p. 440-442.
- [2] D. Vandeplassche, J.-L. Biarrotte, H. Klein, H. Podlech, "The MYRRHA Linear Accelerator", IPAC2011, San Sebastian, Spain, September 2011, p. 2718-2720.
- [3] M. Vossberg, H. Klein, H. Podlech, A. Schempp, A. Bechtold, "4-rod-RFQ for MYRRHA", proceedings of LINAC12, Tel-Aviv, Israel, September 2012, THPB047.
- [4] C. Zhang, H. Klein, D. Mäder, H. Podlech, U. Ratzinger, A. Schempp, R. Tiede, M. Vossberg, "Front-End LINAC Design and Beam Dynamics Simulations for MYRRHA", proceedings of LINAC12, Tel-Aviv, Israel, September 2012, THPB005.
- [5] D. Mäder, H. Klein, H. Podlech, U. Ratzinger, "Status of CH Cavity and Solenoid Design of the 17 MeV Injector for MYRRHA", proceedings of LINAC12, Tel-Aviv, Israel, September 2012, SUPB012.

01 Progress reports and Ongoing Projects

N. Technical R&D - Overall performances (cavity, proto cryomodule tests)